

APPLICATION:

PRODUCT NAME:
ULTRA SPRAY VALVE

JOB NAME:

_____ SPECIAL CONFIGURATION
 CHECK BASE MODEL AND OPTIONS

QUANTITY:

ITEM NO.

MODEL:
 2949 W/ 1.15 GPM NOZZLE

OPTIONS OR MODIFICATIONS:
 OTHER _____

FEATURES

- ULTRA SPRAY VALVE**
- * LOWEST ENERGY USER - 1.15 GPM @ 60 PSI
 - * CLEANS FASTER - TEST PROVEN
 - * ENGINEERED TO LAST - NO 'O' RINGS TO LEAK
 - * INTERCHANGEABLE - FITS ALL BRANDS

- SYSTEM LIMITS**
- * TEMP: 40°F MIN. TO 140°F MAX.
 - * PRESSURE: 200 PSI MAX. STATIC
 - * 1.15 GPM AT 60 PSI

- SHIPPING WEIGHT**
- * 1.5 LBS

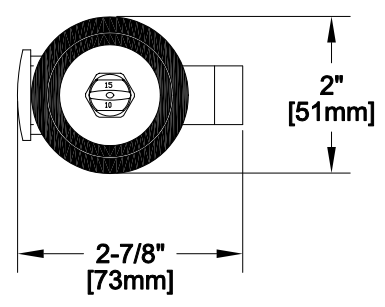
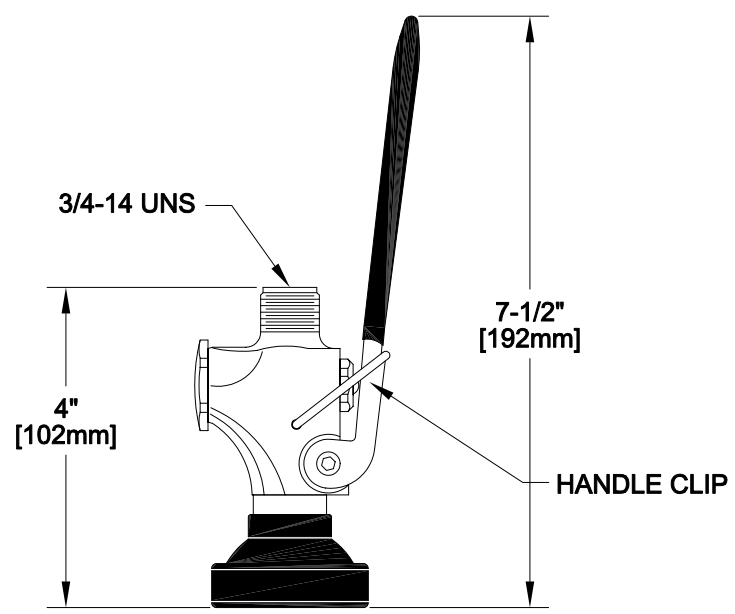

FISHER MANUFACTURING COMPANY
 TOLL FREE: 800-421-6162 - FAX: 800-832-8238
 information@fisher-mfg.com - www.fisher-mfg.com

